

LX-80-30 10 Hz Oceanographic Radar Sensor

RADAR LEVEL SENSOR FOR TIDAL AND WAVE MONITORING

Highlights

- Measurement of water level and automatic calculation of wave parameters
- High sampling rate of up to 10 samples per second allows accurate wave analysis
- Ultra-precise 80 GHz radar technology
- Measurement accuracy ± 2 mm
- Measurement quality not affected by changes in air temperature or density
- Simple installation
- IP68 rated enclosure
- Supports a variety of communication interfaces
- Configurable range of interest
- Easy mounting
- Compatible with Geolux SmartObserver datalogger and Geolux HydroView cloud-based software for real-time remote monitoring
- Low power consumption



Product Description

Geolux LX-80-30 10 Hz oceanographic radar sensor is a high sampling frequency version of the radar level sensor, which is targeted towards tidal monitoring, oceanographic, coastal and maritime applications.

The level sensor uses radar technology to accurately measure the distance between the radar instrument and the surface of the water. The water level measurements are repeatedly performed up to 10 times per second.

An internal wave analysis module uses these water level measurements for advanced wave

analysis. Wave parameters, such as significant wave height, zero up-crossing period, crest period as well as minimum, maximum, mean and median water level are automatically calculated by the radar unit.

The instrument can internally store up to 20 minutes of water level data to be used for calculation of the wave parameters.

The low power consumption of the instrument, the integrated wave analysis module, small form factor and a rugged enclosure make this instrument easy to setup and use.

Detailed Specifications

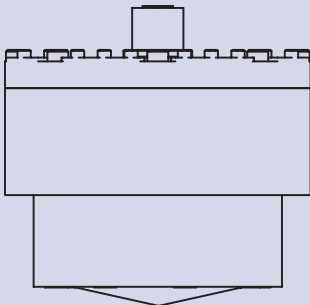
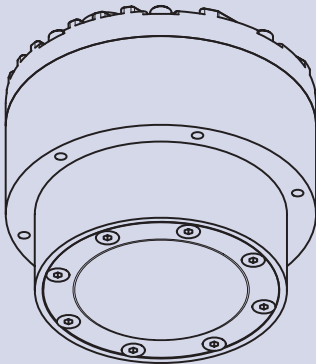
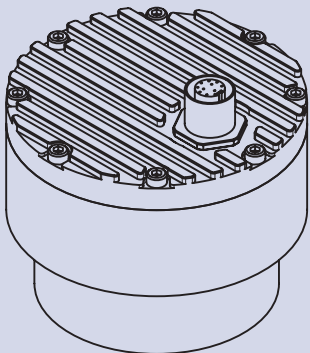

Model	GLX-LX-80-30 10sps
Radar Type	W-band 77-81 GHz FMCW radar
Beam Angle	5°
Detection Distance	30 m
Blind Zone	0.2 m
Resolution	0.5 mm
Accuracy	± 2 mm
Sampling Frequency	2.56 sps / 5.12 sps / 10 sps
Wave Analysis	Internal, analysis window up to 20 minutes
IP Rating	IP68
Serial Interface	1x RS-485 + 1x RS-232, or 2x RS-485
Serial Baud Rate	300 bps to 115200 bps
Serial Protocols	Modbus, GLX-NMEA
Analog Interface	4-20 mA
Other Interfaces	SDI-12
Connector	M12 circular 12-pin
Input Voltage	9 to 27 VDC
Power Consumption	1.85 W standby 0.15 W; sleep 0.03 W;
Maximal Current	< 470 mA
Temperature Range	-40 °C to +85 °C (without heating or coolers)
Enclosure Dimensions	Φ 65 mm x H 78 mm

FCC & CE **APPROVED**

MADE IN **EU**

For more information, contact us:

Phone: +385 1 6701 241

E-mail: geolux@geolux.hr



www.geolux-radars.com